

## Installation Instructions

### INSTRUCTIONS PERTAINING TO A RISK OF FIRE, OR INJURY TO PERSONS.

#### IMPORTANT SAFETY INSTRUCTIONS. SAVE THESE INSTRUCTIONS.

(Failure to follow the warnings and instructions on this sheet could result in fire, injury, failure of product, and/or voiding of warranty.)

- Do not touch while lamp is on. Turn off/unplug and allow to cool before replacing lamp.
- Lamp gets HOT quickly! Contact only switch/plug when turning on.
- Do not touch hot lens, faceplate, cover, or body.
- Keep lamp away from materials that may burn.
- Do not touch lamp at any time. Use a soft cloth. Oil from your skin may damage lamp.
- Do not operate with damaged or missing parts.
- Do not disassemble beyond cover/faceplate and cap removal to facilitate lamp and/or accessory installation or replacement.
- Remove any debris accumulated in the cap periodically.
- Do not install within 10 feet of a pool, spa, or fountain.
- Have installed in accordance with all applicable installation codes and standards by a person familiar with the construction, operation, and hazards involved.
- Use only cable properly rated for the application. **NOTE: Supply conductors in box must be rated for at least 105°C when using an MR16 halogen lamp, and at least 90°C when using the Vision3 LED option.**

#### Notes:

- This fixture should not be mounted in such a way that it is buried or in direct contact with the ground or soil.
- Back end of fixture (behind faceplate) and wiring connections must not be exposed to moisture/water. All mounting, conduit, and wiring must be done in a water tight manner. Failure to do so could result in moisture/water related failure.
- This fixture requires a remote transformer or mount option with integral transformer.
- LED models should only be powered and controlled by compatible transformers and control systems. Contact Vision3 Lighting for approved transformer / controls list. Using non-approved transformers / controls could cause the LED to not operate properly or fail.
- Integral LED options can require up to 13W (10W options) or 15W (12.5W options) during startup, under some circumstances. This must be allowed for when designing system.
- Integral LED options come with a High/Low switch. See 'LED Switching' instructions on next page. Switch will be set to 'High' setting at the factory, unless otherwise specified when ordered.
- Use only Vision3 approved Retrofit MR16 LED options and supplied Heatsink Mount, otherwise LED may overheat and fail.
- LED ratings subject to change without notice. See website or contact V3 for most current info.

**Caution!** Fixture will be hot if lamp is on. Remove power and allow fixture to cool before performing any adjustments or maintenance.

#### Installation for Cast Box (CB) Mount Options:

- Unpack the PA5 Step Light from its shipping container.
- Check to make sure that there are no damaged or missing components
- Loosen, but do not remove, the Cover Set Screws (3X) with a 3/32" hex tool and remove the Cover / Cutoff Assembly from the Faceplate.
- Loosen the Faceplate Screws (2X) with a 1/8" Hex tool and remove the Faceplate Assembly from the Box Assembly. Note: The Socket Mount Assembly will be attached to the Faceplate Assembly.
- Mount the Box Assembly in the wall, per applicable building codes, so that the front face of the box is flush with the outer wall surface. Note: This fixture is not intended for use with combustible surfaces or thermal insulation contact when using the MR16 Halogen lamp option.
- Run conduit and appropriate power supply cable (not supplied) to the Box Assembly, per applicable codes and standards. Note: Supply conductors in

#### For Cast Box (CB) Mount Options

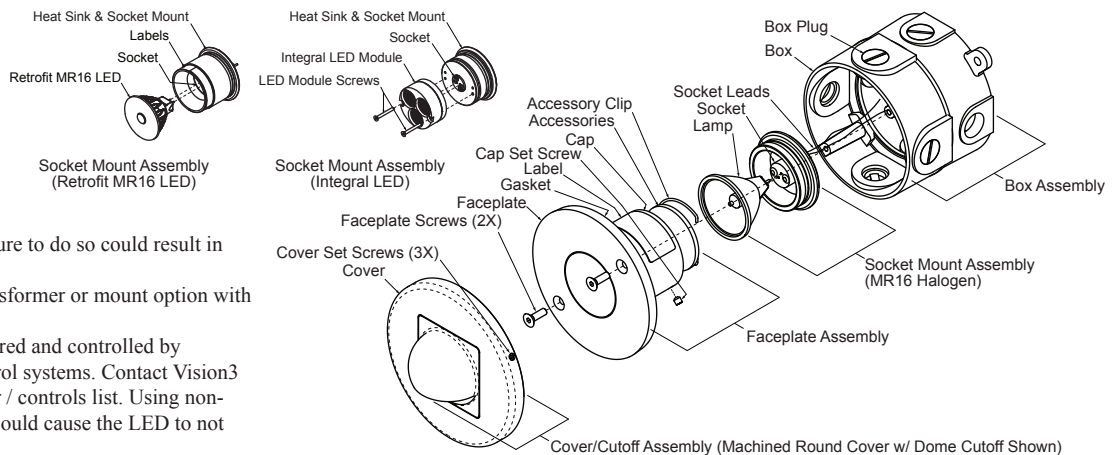

#### For Octagonal Box (OB) Mount Options (Integral LED only)

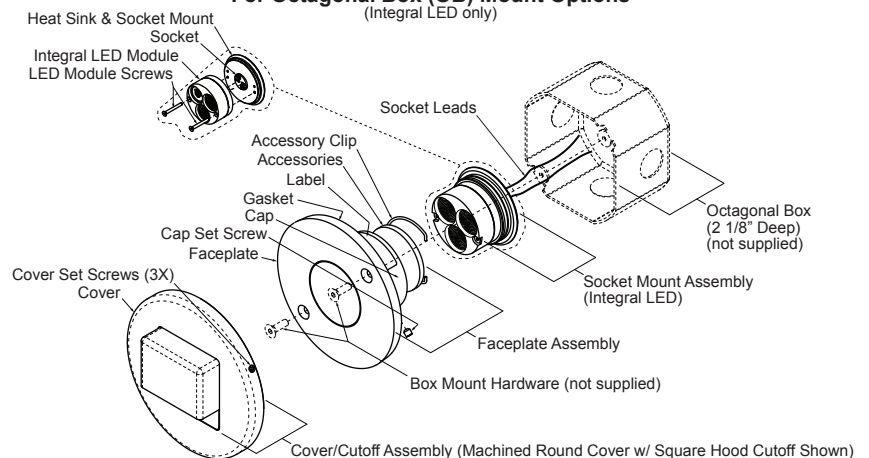

box must be rated for at least 105°C when using the MR16 Halogen lamp option, and 90°C when using the LED lamp option.

- Connect the Socket Leads to the power supply cable using the appropriate connectors (not included) per applicable codes. Note: Be sure that the power being supplied matches the rating on the fixture Label.
- Insert the Faceplate Assembly in to the Box Assembly until the Faceplate meets the wall and the Gasket on the back of the Faceplate is uniformly compressed. Note: Make sure the wiring is not kinked or pinched in any way.

## Installation Instructions

### INSTRUCTIONS PERTAINING TO A RISK OF FIRE, OR INJURY TO PERSONS.

#### IMPORTANT SAFETY INSTRUCTIONS. SAVE THESE INSTRUCTIONS.

(Failure to follow the warnings and instructions on this sheet could result in fire, injury, failure of product, and/or voiding of warranty.)

9. Use the Faceplate Screws (2X) to attach the Faceplate Assembly to the Box Assembly. Note: Make sure the gasket is not pinched. For rough surfaces, use silicone on the back of the Box Gasket to make sure it seals against the wall.
10. Place the Cover/Cutoff Assembly over the Faceplate and properly orient. For some options, the Cover and Cutoff will be two separate parts. Make sure the Cutoff fits properly into the recessed groove in the Cover before installing. Note: Cover Assembly should not be installed in an orientation that allows any eyelids or hoods to fill with water or debris.
11. Gently tighten each Cover Set Screw against the side of the Faceplate. Note: Make sure that the Cover/Cutoff Assembly is tightened on to the Faceplate with all three Cover Set Screws; otherwise, it may loosen.

#### Installation for Octagonal Box (OB) Mount Options:

The Octagonal Box (OB) mounting option is for mounting the PA5 step light in an industry standard sheet metal octagonal outlet box (not supplied). While the PA5 with this mount option will fit in a standard depth octagonal box (1 1/2" deep), there will most likely not be enough room for wiring and wiring connectors. Therefore, a 2 1/8" deep octagonal outlet box must be used (not supplied). This box should be mounted in the wall, per applicable building codes and standard practices, so that the front face of the box is flush with the outer wall surface. Appropriate conduit and power supply cable (neither are supplied) should be ran to the box, per applicable codes and standards. Note: Supply conductors and wiring connectors (neither are supplied) must be rated for at least 90°C. After installation of box / conduit / wire (not supplied), install PA5 as follows:

1. Unpack the PA5 Step Light from its shipping container.
2. Check to make sure that there are no damaged or missing components
3. Loosen, but do not remove, the Cover Set Screws (3X) with a 3/32" hex tool and remove the Cover / Cutoff Assembly from the Faceplate.
4. Connect the Socket Leads to the power supply cable using the appropriate connectors (not included) per applicable codes. Note: Be sure that the power being supplied matches the rating on the fixture Label.
5. Insert the Faceplate Assembly in to the Octagonal Box until the Faceplate meets the wall and the Gasket on the back of the Faceplate is uniformly compressed. Note: Make sure the wiring is not kinked or pinched in any way.
6. Use appropriate Box Mount Hardware (not supplied) to attach the Faceplate Assembly to the Octagonal Box. Make sure the Gasket is not pinched. For rough surfaces, use silicone on the back of the Box Gasket to make sure it seals against the wall. Note: Box Mount Hardware is not supplied as it may vary depending on box installed. The counter-sunk holes on the Faceplate will work with #8 or #10 flat head screws. Use proper size, thread, and length to match box used. Stainless steel should be used to prevent corrosion issues.
7. Place the Cover/Cutoff Assembly over the Faceplate and properly orient. For some options, the Cover and Cutoff will be two separate parts. Make sure the Cutoff fits properly into the recessed groove in the Cover before installing. Note: Cover Assembly should not be installed in an orientation that allows any eyelids or hoods to fill with water or debris.
8. Gently tighten each Cover Set Screw against the side of the Faceplate. Note: Make sure that the Cover/Cutoff Assembly is tightened on to the Faceplate with all three Cover Set Screws; otherwise, it may loosen.

#### Lamp Maintenance:

1. Remove power from fixture and let cool before touching. **Caution! Luminaire may still be hot!**
2. Loosen the Cover Set Screws (3X) using a 3/32" hex tool (do not remove screws) and remove the Cover from the Faceplate.
3. Loosen the Faceplate Screws (2X) and remove the Faceplate Assembly from the Box Assembly. Note: Be careful with the Socket Leads when

removing the Faceplate Assembly.

4. Loosen the Cap Set Screw using a 3/32" hex tool – do not remove screw!
5. Remove the Socket Mount Assembly from the Faceplate Assembly.
6. Replace lamp/LED.

#### For MR16 Halogen Lamp:

- a. Pull lamp straight out. **Caution! Lamp may still be hot! Be sure lamp has cooled before touching.**
- b. Inspect socket for any damage.
- c. Clean inside of fixture and Cap with a clean dry cloth.
- d. Push new lamp straight in, being careful to align pins. **Note:** Replacement lamp must not exceed ratings on Label.

#### For Integral LED Module:

- a. Loosen and remove the LED Module Screws.
- b. Pull LED straight out. Do not twist or the pins will break off in the socket. **Caution! LED may still be hot! Be sure LED has cooled before touching.**
- c. Clean the grease off of the Heatsink top surface using a rag dipped in alcohol.
- d. Inspect the socket for any damage.
- e. If the replacement LED Module does not come with a thermal transfer pad on the base, apply a thin layer of thermal grease (not supplied) to the surface of the Heatsink that will contact the bottom of the LED Module.
- f. Align the pins on the LED Module with the socket and push straight in. Do not twist or push in at an angle or the pins may be damaged.
- g. Install and tighten the LED Module Screws. **Caution!** Over tightening of screws could crack the LED Module case.

#### For Retrofit MR16 LED Lamp:

- a. Pull lamp straight out. **Caution! Lamp may still be hot! Be sure lamp has cooled before touching.**
  - b. Inspect socket for any damage.
  - c. Clean inside of fixture and Cap with a clean dry cloth.
  - d. Push new lamp straight in, being careful to align pins. Make sure Retrofit MR16 Lamp fully contacts Heatsink Mount, otherwise lamp may overheat and fail prematurely. **Note:** Replacement lamp must not exceed ratings on Label. Only use Vision3 approved Retrofit MR16 Lamp and supplied Heatsink Mount, otherwise LED may overheat and fail.
7. Re-install Socket Mount Assembly in to Faceplate Assembly.
  8. Tighten Cap Set Screw with the 3/32" hex tool so that is just bottoms out.
  9. Insert the Faceplate Assembly in to the Box Assembly. Note: Make sure the wiring is not kinked or pinched in any way.
  10. Use the Faceplate Screws (2X) to attach the Faceplate Assembly to the Box Assembly.
  11. Place the Cover Assembly over the Faceplate Assembly as far as it will go, and properly orient. Note: Cover Assembly should not be installed in an orientation that allows any eyelids or hoods to fill with water or debris.
  12. Gently tighten each Cover Set Screw against the side of the Faceplate. Note: Make sure that the Cover/Cutoff Assembly is tightened on to the Faceplate with all three Cover Set Screws; otherwise, it may loosen.

#### LED Switching (on certain models):

1. Remove the Faceplate Assembly to gain access to the Integral LED Module as explained in Lamp Maintenance steps 1 thru 5.
2. Inspect for damage. Replace any damaged parts, if necessary.

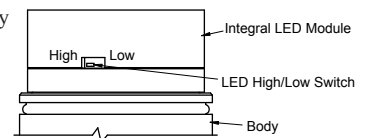

## Installation Instructions

**INSTRUCTIONS PERTAINING TO A RISK OF FIRE, OR INJURY TO PERSONS.**

**IMPORTANT SAFETY INSTRUCTIONS. SAVE THESE INSTRUCTIONS.**

(Failure to follow the warnings and instructions on this sheet could result in fire, injury, failure of product, and/or voiding of warranty.)

3. Clean inside of fixture with a clean, damp cotton cloth.
4. Find LED High/Low Switch on side of Integral LED Module.
5. Using a pin, small nail, etc, flip the switch in the desired direction. See the LED Module Switch sketch for which direction corresponds to which setting.
6. Re-assemble as explained in Lamp Maintenance steps 7 thru 12.

### Accessory Maintenance:

1. Remove the Faceplate Assembly to gain access to the accessories, as explained in Lamp Maintenance steps 1 thru 5.
2. Remove Accessory Clip from Cap.
3. Carefully remove Accessories from Cap, if any.
4. Inspect Cap, Accessories, and Clip for damage. Replace if necessary.
5. Clean Cap and Accessories with a clean, damp cotton cloth.
6. Carefully install new Accessories into Cap.
7. Compress Clip and push into Cap until it holds Accessories tightly in Cap.
8. Re-assemble as explained in Lamp Maintenance steps 7 thru 12.